

Specification

For

LCD Module

TS12864A-2(V1.0)

TABLE OF CONTENTS

- 1.0 INTRODUCTION
- 1.1 FEATURE
- 2.0 DIMENSIONAL DIAGRAM
- 3.0 MECHANICAL SPECIFICATIONS
- 4.0 MAX STANDARD VALUE
- 5.0 ELECTRICAL CHARACTERISTICS
- 6.0 OPTICAL CHARACTERISTICS
 - 6.1 OPTICAL MEASUREMENT SYSTEM
 - 6.2 DEFINITION OF θ and Φ
 - 6.3 DEFINITION OF CONTRAST RATIO C_r
 - 6.4 DEFINITION OF OPTICAL RESPONSE TIME
- 7.0 INTERFACE PIN FUNCTION DESCRIPTION
- 8.0 BLOCK DIAGRAM
 - 8.1 POWER SUPPLY BLOCK DIAGRAM
- 9.0 TIMING CHARACTERISTICS
- 10.0 DISPLAY CONTROL INSTRUCTION

1.0 INTRODUCTION

This USER'S MANUAL is introduced the outside dimensions, optical characteristics, electrical characteristics, interface, controller commands, etc. of the custom design LCD module.

1.1 FEATURE

- (1) Display mode: STN ,blue color, Positive, Transflective
- (2) Display format: 128*64 Dots
- (3) Driving method: 1/64 Duty, 1/9 Bias
- (4) Viewing direction: 6 o'clock
- (5) Interface Input Data : 8-Bit
- (6) Back light: LED (white)

2.0 DIMENSION DIAGRAM

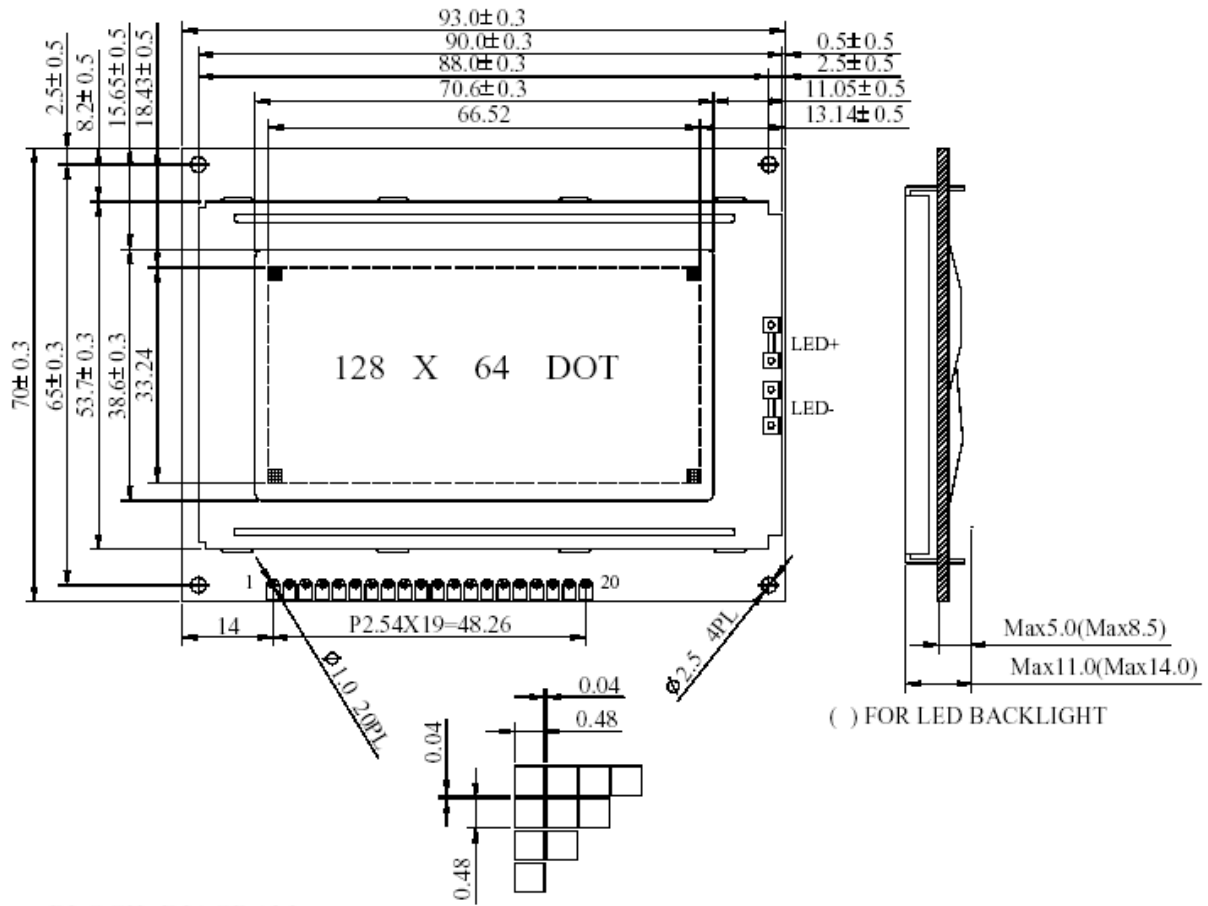

⊗ BLOCK DIAGRAM:

1	2	3	4	5	6	7	8	9	10	11	12	13	14	15	16	17	18	19	20
VSS	VDD	VO	D/I	R/W	E	DB0	DB1	DB2	DB3	DB4	DB5	DB6	DB7	CS1	CS2	RSTB	VOUT	BLA	BLK

3.0 MECHANICAL SPECIFICATIONS

ITEM	STANDARD VALUE	UNIT
DOTS	128X-64	-
DOT SIZE	0.48X0.48	mm
DOT PITCH	0.52X0.52	mm
MODULE DIMENSION	93.0(W) × 70.0(H) × 14.5(T)	mm
EFFECTIVE DISPLAY AREA	70.7(W) × 38.8(H)	mm

4.0 MAX STANDARD VALUE

ITEM	SYMBOL	MIN.	TYPE	MAX	UNIT
OPERATING TEMPERATURE	Top	-20	25	70	°C
STORAGE TEMPERATURE	Tst	-30	/	80	°C
INPUT VOLTAGE	VI	VSS	/	VDD	V
SUPPLY VOLTAGE FOR LOGIC	VDD-VSS	Vss-0.3	/	5.2	V
SUPPLY VOLTAGE FOR LCD	VDD-V0	/	10.5	/	V

5.0 ELECTRICAL CHARACTERISTICS

ITEM	SYMBOL	CONDITION	MIN.	TYP.	MAX.	UNIT
SUPPLY VOLTAGE FOR LOGIC	$V_{DD}-V_{SS}$	Ta = 25 °C	4.5	5.0	5.5	V
SUPPLY VOLTAGE FOR LCD	$V_{DD}-V_{O}$ (VOP)	Ta = 25 °C	10	10.5	11.5	V
INPUT HIGH VOL.	V_{IH}	Ta = 25 °C	2.0	-	VDD	V
INPUT LOW VOL.	V_{IL}	Ta = 25 °C	VSS	-	0.8	V
OUTPUT HIGH VOL.	V_{OH}	Ta = 25 °C	2.4	-	-	V
OUTPUT LOW VOL.	V_{OL}	Ta = 25 °C	-	-	0.4	V
SUPPLY CURRENT	IDD	VDD = 3.0V	-	100	500	μA

6.0 OPTICAL CHARACTERISTICS

No	Item	Symbol	Measurement temperature	MIN.	TYP.	MAX.	Unit	
1	Contrast Ratio	Cr	25°C	2.60	3.17			
2	Response Time	Rise time	Tr	25°C		100	120	mS
		Fall time	Tf	25°C		60	80	mS
		On time	Ton	25°C		150	170	mS
		Off time	Toff	25°C		80	120	mS
3	Viewing Angle	6H, $\Phi=0^\circ$	$\theta 1$	25°C	55			Deg.
		12H, $\Phi=180$	$\theta 2$	25°C	0			Deg.
		$\Phi=90^\circ$	$\theta 3$	25°C	45			Deg.
		$\Phi=270$	$\theta 4$	25°C	45			Deg.
4	Frame Frequency		25°C	32	76	200	Hz	

6.1 OPTICAL MEASUREMENT SYSTEM

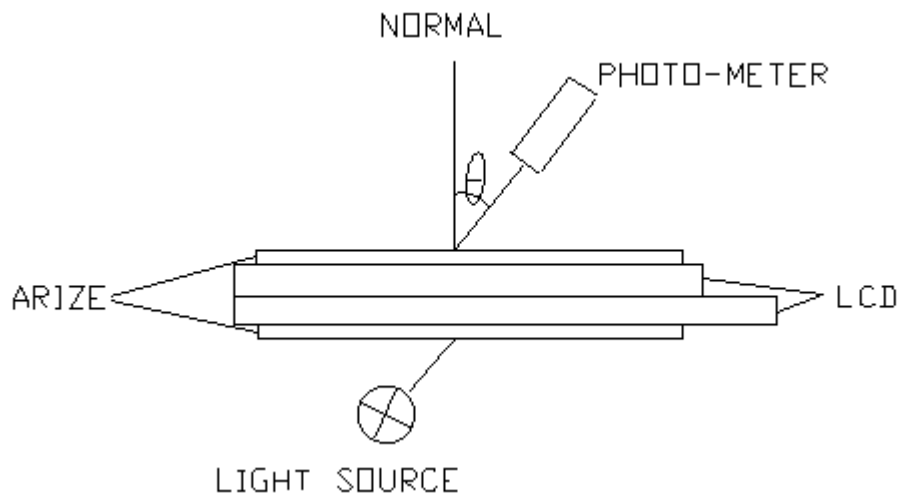

6.2 DEFINITION OF θ AND ϕ

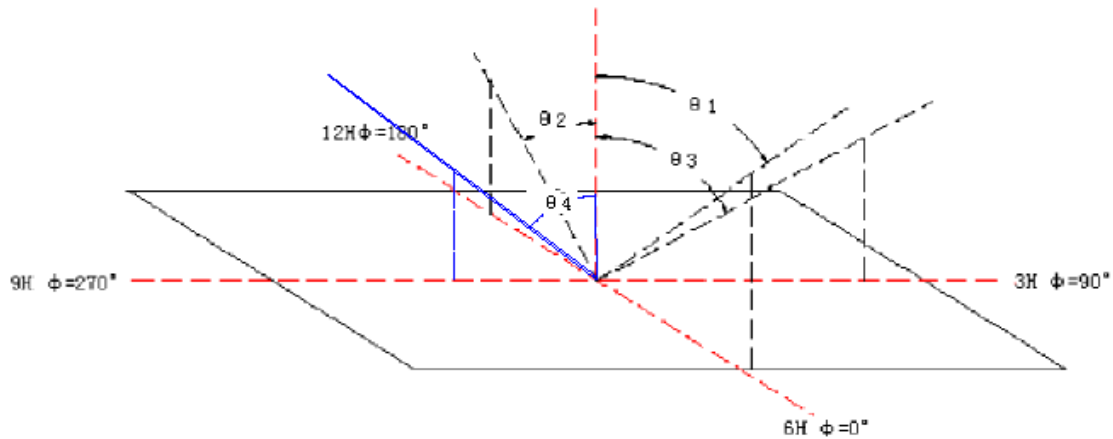

6.3 DEFINITION OF CONTRAST RATIO C_r

DEFINITION:

$$C_r = \frac{\text{Brightness of non-selection dot (} b_{ns} \text{)}}{\text{Brightness of selection dot (} b_s \text{)}}$$

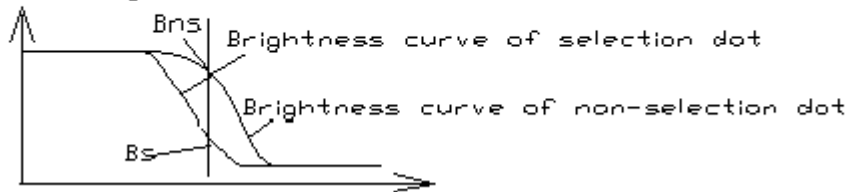

6.4 DEFINITION OF OPTICAL RESPONSE TIME

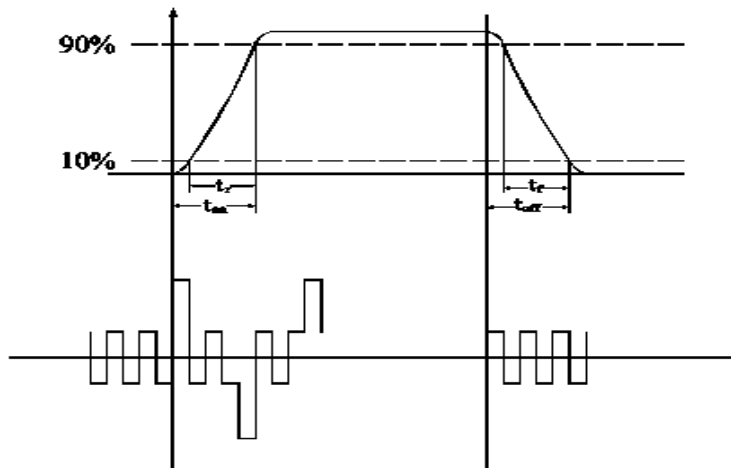

7.0 INTERFACE PIN FUNCTION DESCRIPTION

PIN NO	SYMBOL	FUNCTION
1	VSS	Ground(0V)
2	VDD	Power supply for logic circuit(5V)
3	VO	Operating voltage for LCD driving(Variable)
4	D/I	H :Data input ; L : Instruction code input
5	R/W	H: Data Read (LCM to MPU) ; L: Data Write (MPU to LCM)
6	E	Enable signal. Write mode (R/W = L) → data of DB<0:7> is latched at the falling edge of E. Read mode (R/W = H) → DB<0:7> appears the reading data while E is at high leve
7~14	DB0-DB7	Data bus. There state I/O common terminal.
15	CSA	Active High, left chip selection
16	CSB	Active High, right chip selection
17	RESET	Reset signal, active low
18	VOUT	Negative voltage output(-15V max)
19	BLA	Backlight (+5V)
20	BLK	Backlight (0V)

8.0 BLOCK DIAGRAM

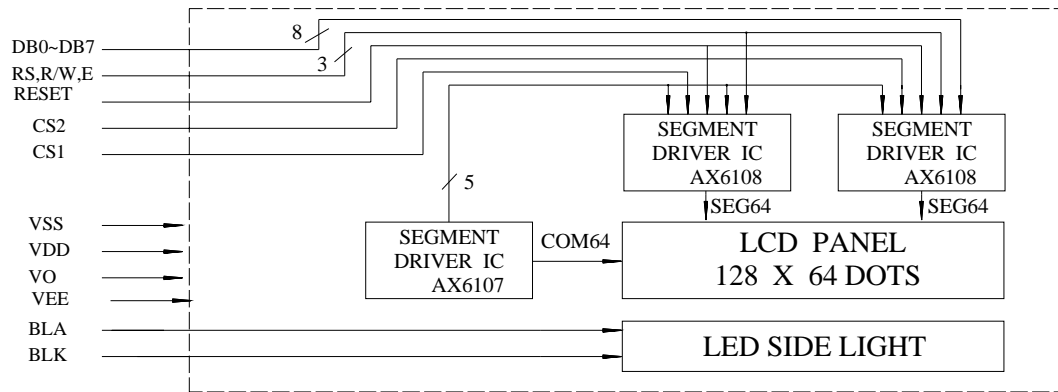

8.1 POWER SUPPLY BLOCK DIAGRAM

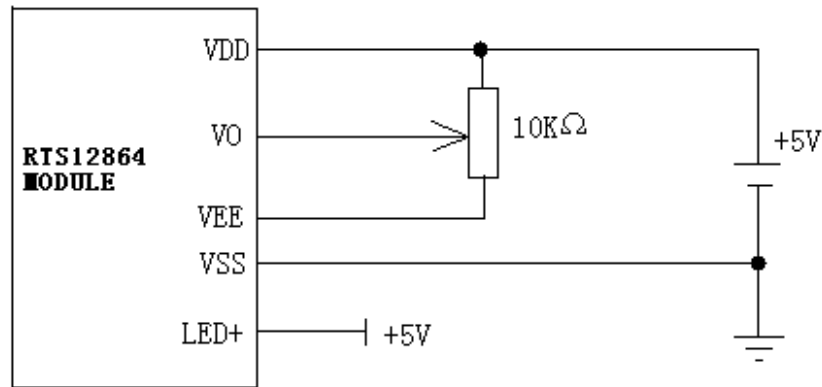

9.0 TIMING CHARACTERISTICS

Item	Symbol	Min	Typ	Max	Unit	Note
E cycle time	t_{CYC}	1,000	--	--	ns	1, 2
E high level width	P_{WEH}	400	--	--	ns	1, 2
E low level width	P_{WEL}	400	--	--	ns	1, 2
E rise time	t_r	--	--	25	ns	1, 2
E fall time	t_f	--	--	25	ns	1, 2
Address setup time	t_{AS}	200	--	--	ns	1, 2
Address hold time	t_{AH}	10	--	--	ns	1, 2
Data setup time	t_{DSW}	200	--	--	ns	1
Data delay time	t_{DDR}	--	--	320	ns	2, 3
Data hold time (Write)	t_{DHW}	10	--	--	ns	1
Data hold time (Read)	t_{DHR}	20	--	--	ns	2

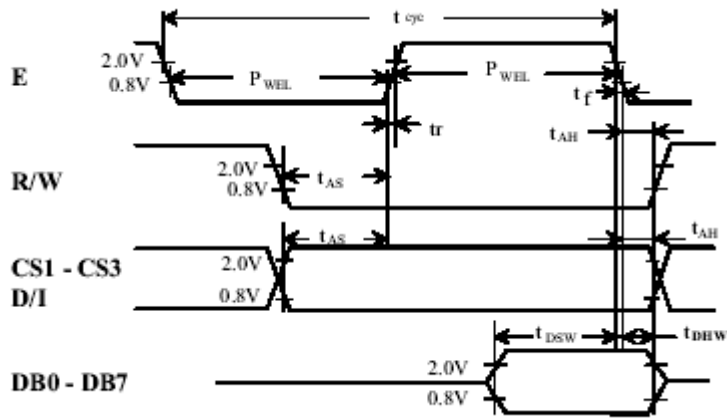

MPU Write Timing

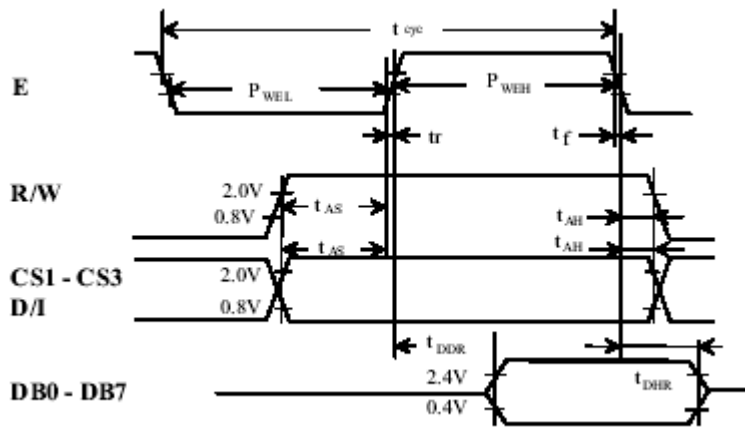

MPU Read Timing

10.0 Display control instruction

The display control instructions control the internal state of the NT7107. Instruction is received from MPU to NT7108 for the display control. The following table shows various instructions.

Instruction	RS	R/W	DB7	DB6	DB5	DB4	DB3	DB2	DB1	DB0	Function	
Display on/off	L	L	L	L	H	H	H	H	H	L/H	Controls the display on or off. Internal status and display RAM data is not affected. L: OFF, H: ON	
Set address (Y address)	L	L	L	H	Y address (0 - 63)						Sets the Y address in the Y address counter.	
Set page (X address)	L	L	H	L	H	H	H	Page (0 - 7)			Sets the X address at the X address register.	
Display start line (Z address)	L	L	H	H	Display start line (0 - 63)						Indicates the display data RAM displayed at the top of the screen.	
Status read	L	H	Busy	L	On/Off	Reset	L	L	L	L	Read status. BUSY L: Ready H: In operation ON/OFF L: Display ON H: Display OFF RESET L: Normal H: Reset	
Write display data	H	L	Write data									Writes data (DB0:7) into display data RAM. After writing instruction, Y address is increased by 1 automatically.
Read display data	H	H	Read data									Reads data (DB0:7) from display data RAM to the data bus.

DISPLAY ON/OFF

RS	R/W	DB7	DB6	DB5	DB4	DB3	DB2	DB1	DB0
0	0	0	0	1	1	1	1	1	D

The display data appears when D is 1 and disappears when D is 0. Though the data is not on the screen with D = 0, it remains in the display data RAM. Therefore, you can make it appear by changing D = 0 into D = 1.

SET ADDRESS (Y ADDRESS)

S	R/W	DB7	DB6	DB5	DB4	DB3	DB2	DB1	DB0
0	0	0	1	AC5	AC4	AC3	AC2	AC1	AC0

Y address (AC0 - AC5) of the display data RAM is set in the Y address counter. An address is set by instruction and increased by 1 automatically by read or write operations of display data.

SET PAGE (X ADDRESS)

RS	R/W	DB7	DB6	DB5	DB4	DB3	DB2	DB1	DB0
0	0	1	0	1	1	1	AC2	AC1	AC0

X address (AC0 - AC2) of the display data RAM is set in the X address register. Writing or reading to or from MPU is executed in this specified page until the next page is set.

DISPLAY START LINE (Z ADDRESS)

RS	R/W	DB7	DB6	DB5	DB4	DB3	DB2	DB1	DB0
0	0	1	1	AC5	AC4	AC3	AC2	AC1	AC0

Z address (AC0 - AC5) of the display data RAM is set in the display start line register and displayed at the top of the screen. When the display duty cycle is 1/64 or others(1/32 - 1/64), the data of total line number of LCD screen, from the line specified by display start line instruction, is displayed.

STATUS READ

RS	R/W	DB7	DB6	DB5	DB4	DB3	DB2	DB1	DB0
0	1	BUSY	0	ON/OFF	RESET	0	0	0	0

- **BUSY**
When BUSY is 1, the Chip is executing internal operation and no instructions are accepted.
When BUSY is 0, the Chip is ready to accept any instructions.
- **ON/OFF**
When ON/OFF is 1, the display is off.
When ON/OFF is 0, the display is on.
- **RESET**
When RESET is 1, the system is being initialized.
In this condition, no instructions except status read can be accepted.
When RESET is 0, initializing has finished and the system is in the usual operation condition.

WRITE DISPLAY DATA

RS	R/W	DB7	DB6	DB5	DB4	DB3	DB2	DB1	DB0
1	0	D7	D6	D5	D4	D3	D2	D1	D0

Writes data (D0 - D7) into the display data RAM. After writing instruction, Y address is increased by 1 automatically.

READ DISPLAY DATA

RS	R/W	DB7	DB6	DB5	DB4	DB3	DB2	DB1	DB0
1	1	D7	D6	D5	D4	D3	D2	D1	D0

Reads data (D0 - D7) from the display data RAM. After reading instruction, Y address is increased by 1 automatically.